

Red Sea REEFER™

250 G2 / 300 G2

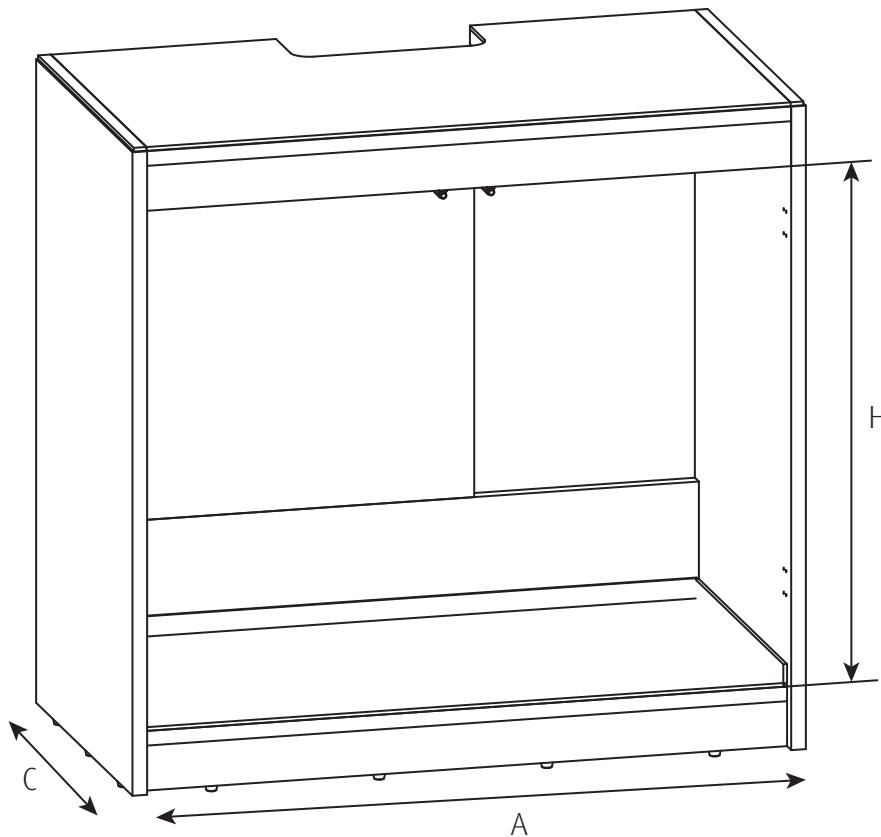

	250 G2	300 G2
Sump Compartment "A"	86cm/ 33 55/64"	86cm/ 33 55/64"
Depth(rear wall to door) "C"	46cm/ 18 7/64"	53.5cm/ 21 1/16"
Height (Cabinet floor to Top header) "H"	70 cm / 27 9/16"	70 cm / 27 9/16"